

Power amplifier for 1.9 GHz at 3 V

Application report

In this note some results of measurements are described performed on a RF amplifier for 1.9GHz applications. The amplifier is build up from three bipolar transistors, the broadband transistor BFG540/X and the new RF power transistors BFG10/X and BFG11/X.

The amplifier, a demonstration board showing the BFG540, BFG10 and BFG11 line-up, is developed for maximum gain and efficiency under the conditions : output power 26dBm, supply voltage 3.6V, frequency 1900MHz. The amplifier gives about 25dB gain at 26 dBm output power. If more gain is needed a pre-stage could be added with the BFG505 transistor. This could increase the gain with about 10dB, without a significant decrease of efficiency. Since the amplifier is build up with bipolar transistors no supply voltage is lost caused by switches, as in GaAs FET designs. The total 3 x 1.2V supply voltage is available for operation.

General characteristics:

Supply voltage	3.3 - 3.6 V	
Frequency	1880 - 1920 MHz	
Gain	> 20 dB	Measured : 25 dB
Output power	26 dBm	
Efficiency	40 %	@ 26 dBm output power
Intermodulation IM2 *)	30dBc	@ 23 dBm PEP
Type of operation	pulsed	Duty cycle 1 - 12.5%
Printed circuit board size	21 x 13 mm	
Printed circuit board	FR4 (Er=4.7, h=0.5mm)	Epoxy
Components	BFG540/X BFG10/X BFG11/X BC807/BC817 resistors capacitors	Package: SOT143/X **) SOT143/X **) SOT143/X **) small npn and pnp transistors in SOT23 used for biasing the BFG540/X, BFG10/X and BFG11/X philips 0603 Philips 0603

*) Important for the Japanese PHP system only.

**) Also available in SOT143

Circuit diagram

For the development of a 1.9GHz amplifier, impedance information is needed about the RF transistors for designing the matching circuits. The amplifier is build up with 3 stages, a BFG540 operating in class A, and the BFG10 and BFG11 operating in class AB. The design of the class A, BFG540 stage can be done with S-parameter information available on floppy disc. The conjugate match input and load impedances are given in the table below. The design of the BFG10 and BFG11 stages can be done by using measured impedances given in the next table:

Transistor	Operation in class	Input impedance		Opt. load impedance	
		Re [Ω]	Im [Ω]	Re [Ω]	Im [Ω]
BFG540	A, [30mA/3.6V]	7.1	13.9	44.6	40.1
BFG10	AB, [Ube=0.72V]	5.6	16.0	12.4	-1.2
BFG11	AB, [Ube=0.72V]	8.4	16.3	12.4	-1.2

In appendix A the circuit diagram is shown of the amplifier. The RF amplification part is build up with the transistors BFG540/X, BFG10/X and BFG11/X and matching circuits. The matching is done by shunt and series capacitors, series transmission lines and shorted stubs. A capacitor with a value of 8.2 pF is about series resonance at 1.9 GHz.

The BFG540/X transistor is operating in Class A at a collector current of 30mA. At this current the BFG540/X gives optimum performance.

The stabilization of the collector current is done by a low frequency PNP transistor which compares the voltage drop on a collector resistance of the BFG540/X with a voltage determined by the voltage on Vc. This bias circuit gives a biasing which is independent of temperature and Hfe. The voltage drop on R3 is about 0.3V.

A voltage of 0V on pin Vc gives a collector current of 30mA. A voltage of 3.0V on pin Vc switches the BFG540/X off.

The low frequency transistor BC817 is also used as a diode. Connecting the collector to the emitter gives a forward voltage of about 0.7V at a low current (1mA).

Under pulsed conditions the pin Vc should be applied with **negative** pulses of 0V.

The BFG10/X and BFG11/X are operating in class AB. The bias voltage of the BFG10/X and BFG11/X is set to about 0.72V during RF. This voltage is pulsed and derived from the biascircuit of the Class A bias circuit.

A layout of the circuit at a scale of 10 : 1 can be found in appendix B.

Measurement results

In appendix C to F the results of measurements are given. The measurements are all performed under pulsed conditions with a duty cycle of 10%.

Appendix C Gain and efficiency vs. Pout.

These pictures show the performance of the amplifier for 3.6V supply voltage.

Appendix D Pout and efficiency vs. the supply voltage

This plot shows the output for a constant input power when the supply voltage is varied over the range 3.0 to 4.2V.

Appendix E Gain and efficiency vs. frequency

The gain drops about 0.5dB over the frequency range from 1880 MHz to 1900 MHz.

Appendix F Pout and efficiency vs. Control voltage

When the control voltage is changed from 0V to 3V the output power is decreasing. The output power vs. the control voltage is shown in this plot.

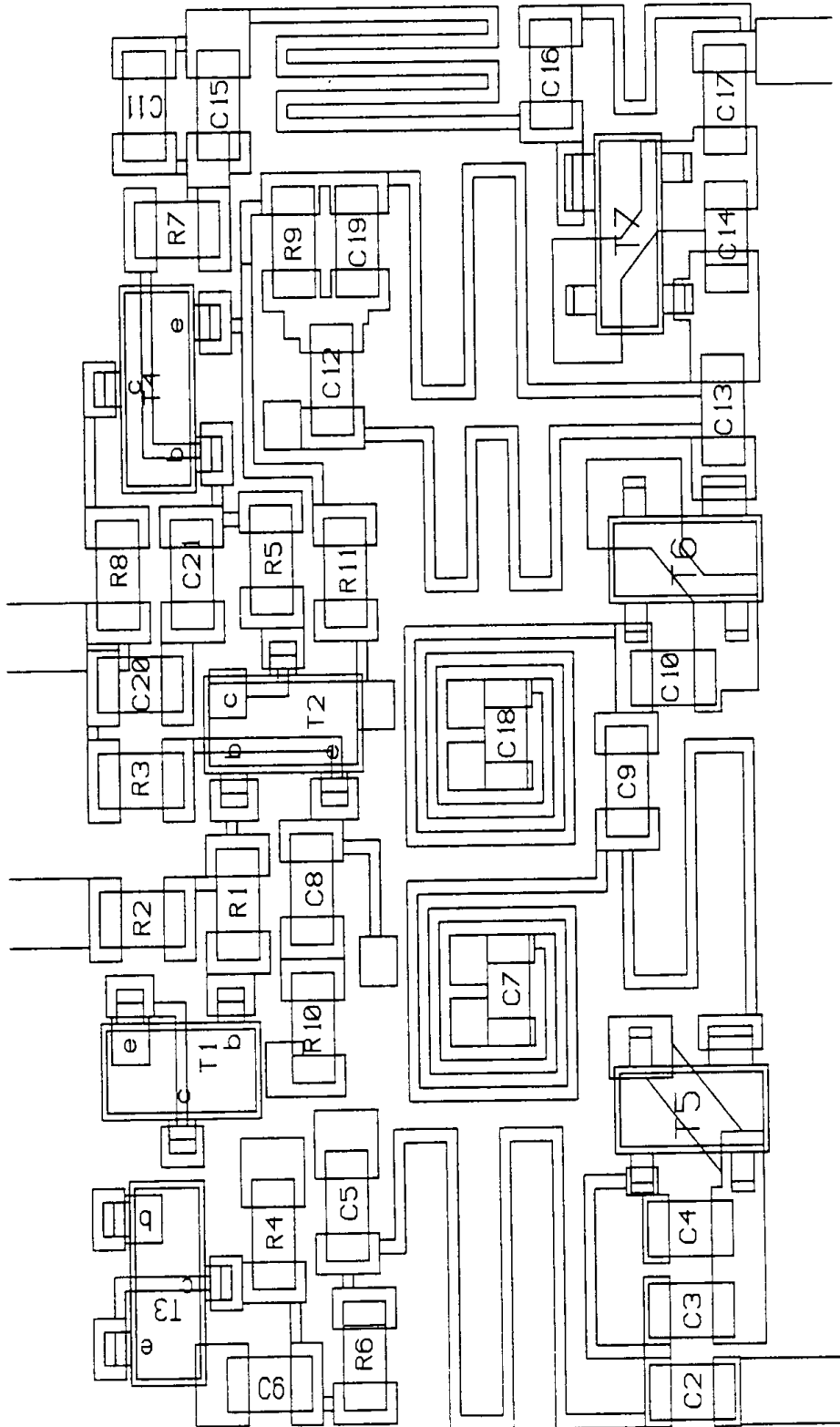

"RL027"

Componentlist 1.9 GHz Power Amplifier

T1	BC807	R1	330E	C1	-
T2	BC807	R2	3K3	C2	8p2
T3	BC817	R3	10E	C3	0p68
T4	BC817	R4	820E	C4	3p3
T5	BFG540/X	R5	220E	C5	8p2
T6	BFG10/X	R6	47E	C6	1n
T7	BFG11/X	R7	2K7	C7	8p2
		R8	220E	C8	-
		R9	180E	C9	2p2
		R10	-	C10	2p7
		R11	15E	C11	1n
				C12	8p2
				C13	3p9
				C14	3p0
				C15	10p
				C16	3p9
				C17	2p2
				C18	8p2
				C19	8p2
				C20	10n
				C21	560p

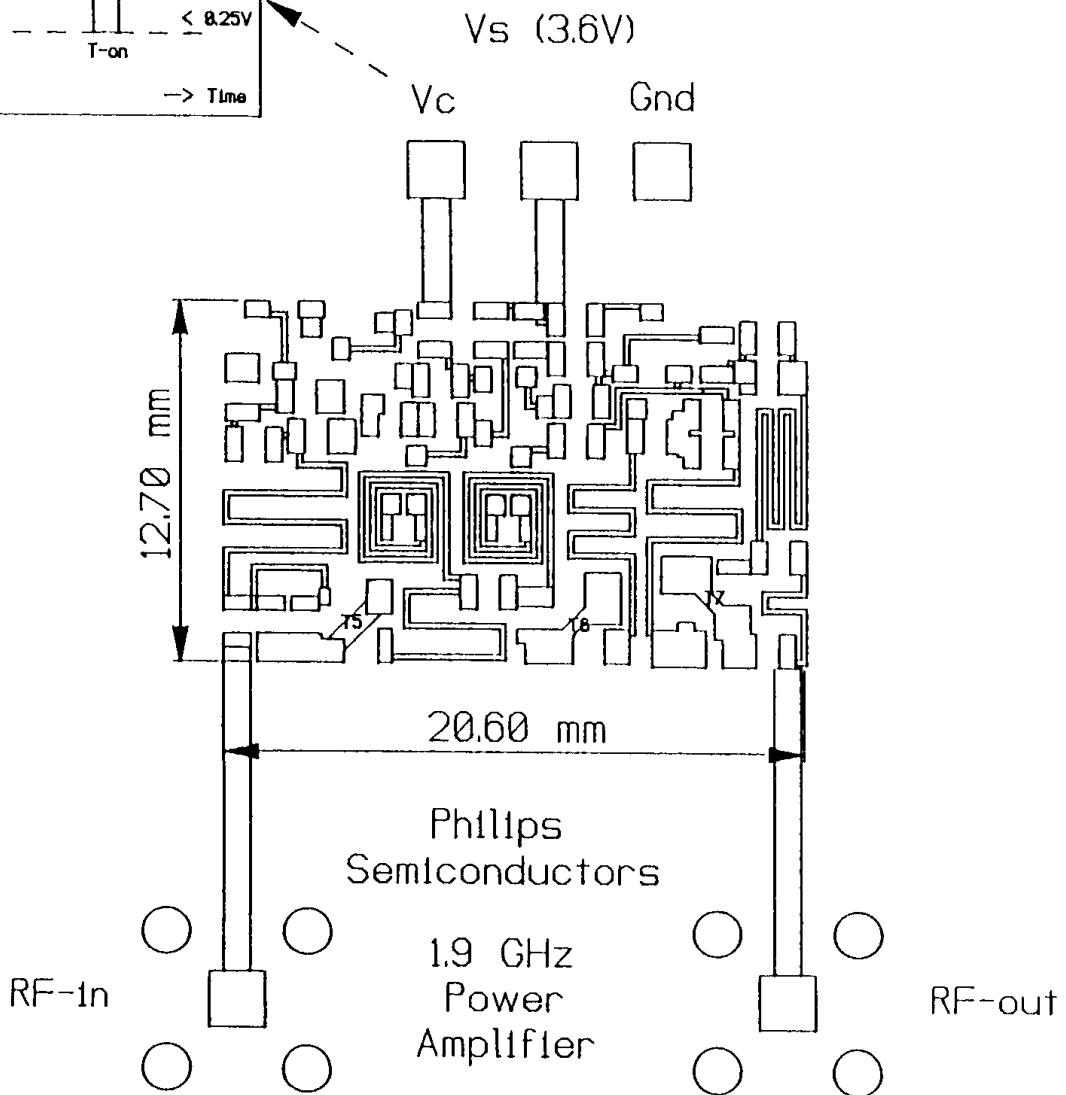
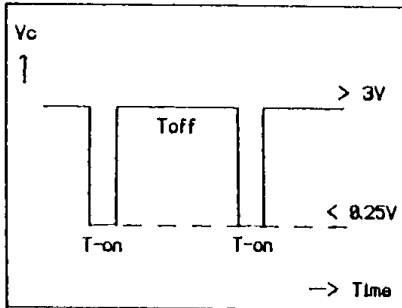

Gain & Efficiency

1.9 GHz amplifier

(BFG540/X - BFG10/X - BFG11/X)

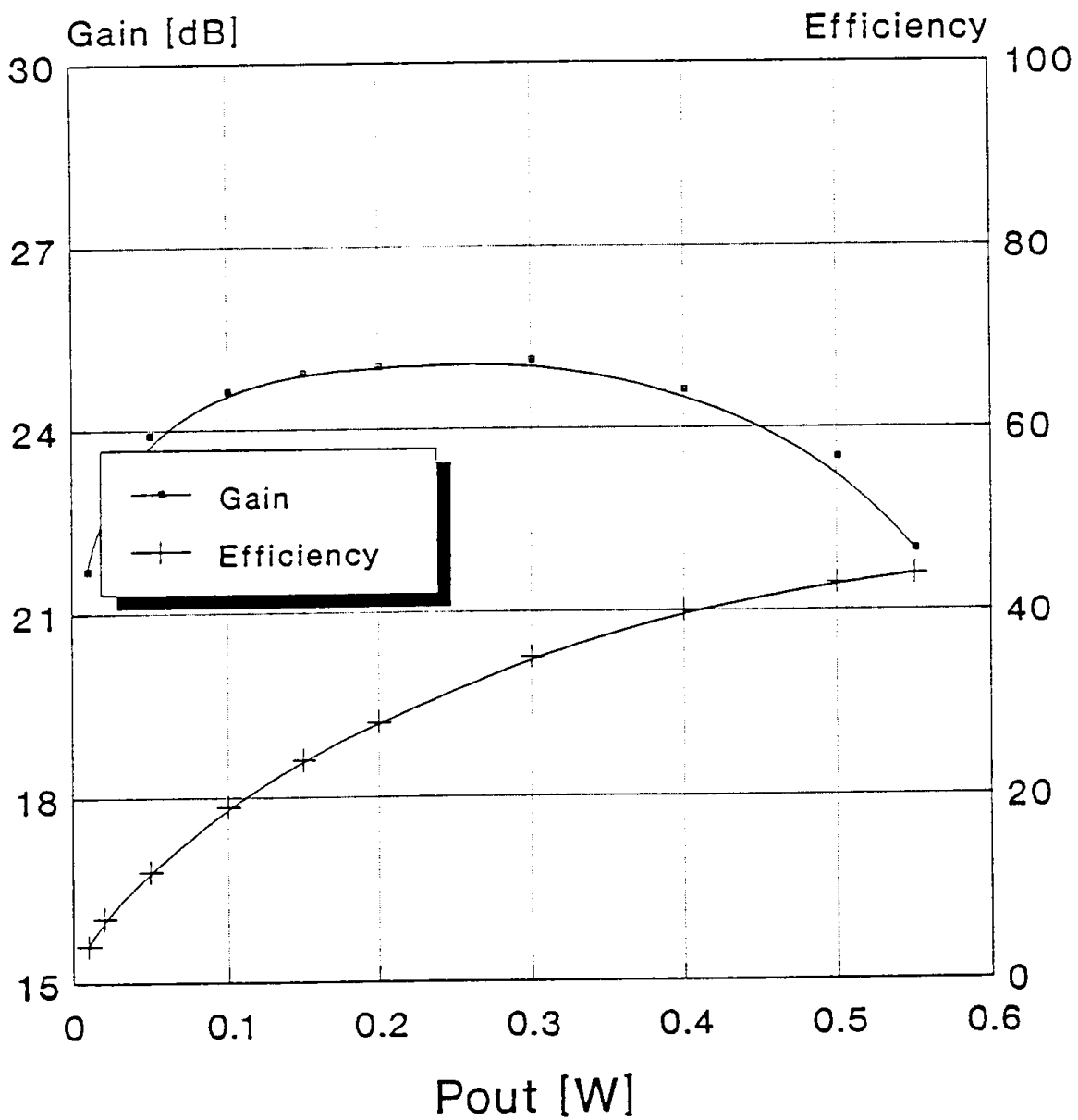

F=1.88GHz, Control=0.00V
R06_V05\V001

Pout & Eff. vs. supply voltage

1.9 GHz amplifier

(BFG540/X - BFG10/X - BFG11/X)

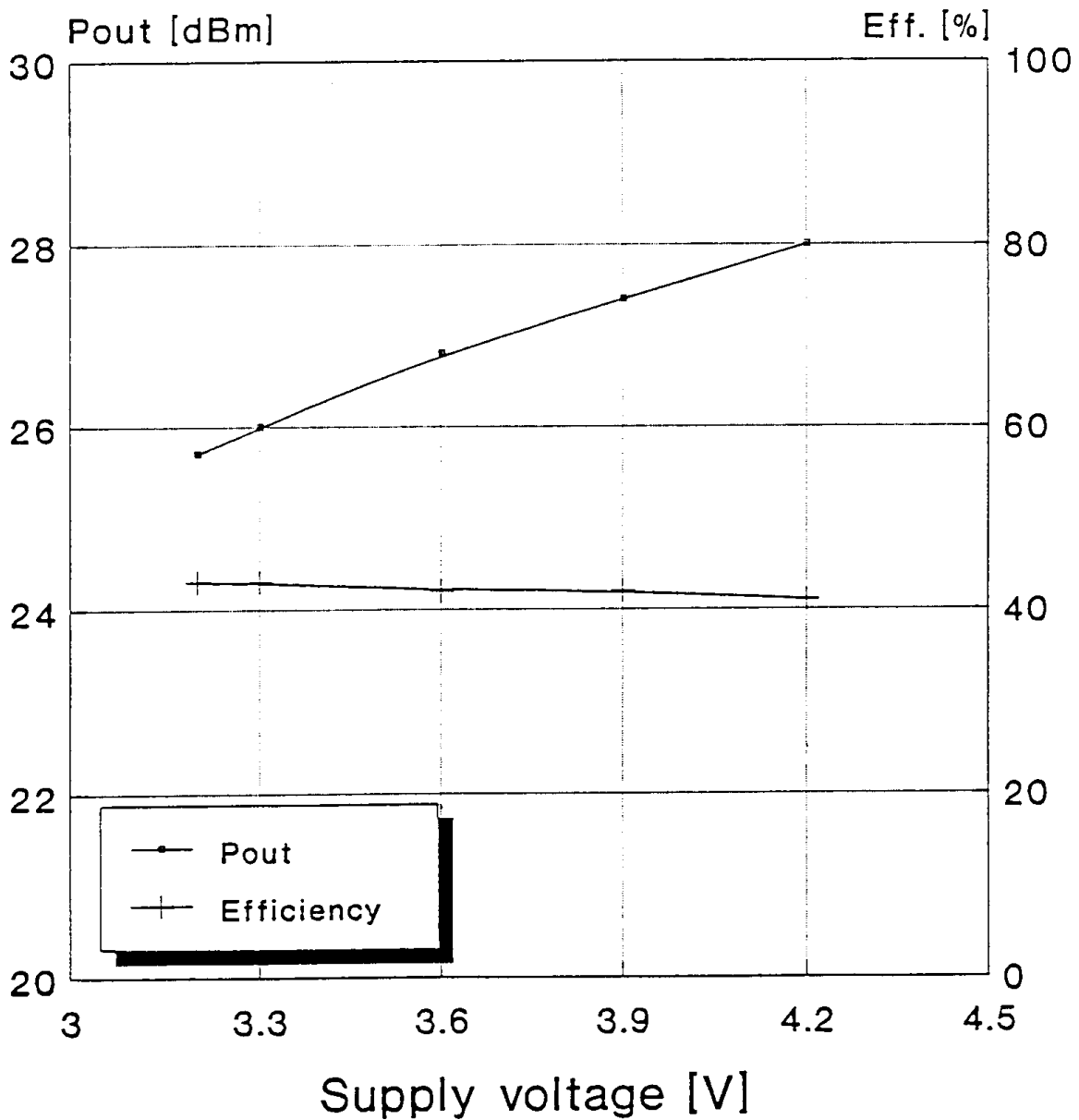

F=1.88GHz, Contr=0.00V, Pin=3dB
"R06_V05\V003"

Gain & Efficiency vs. Frequency

1.9 GHz amplifier

(BFG540/X - BFG10/X - BFG11/X)

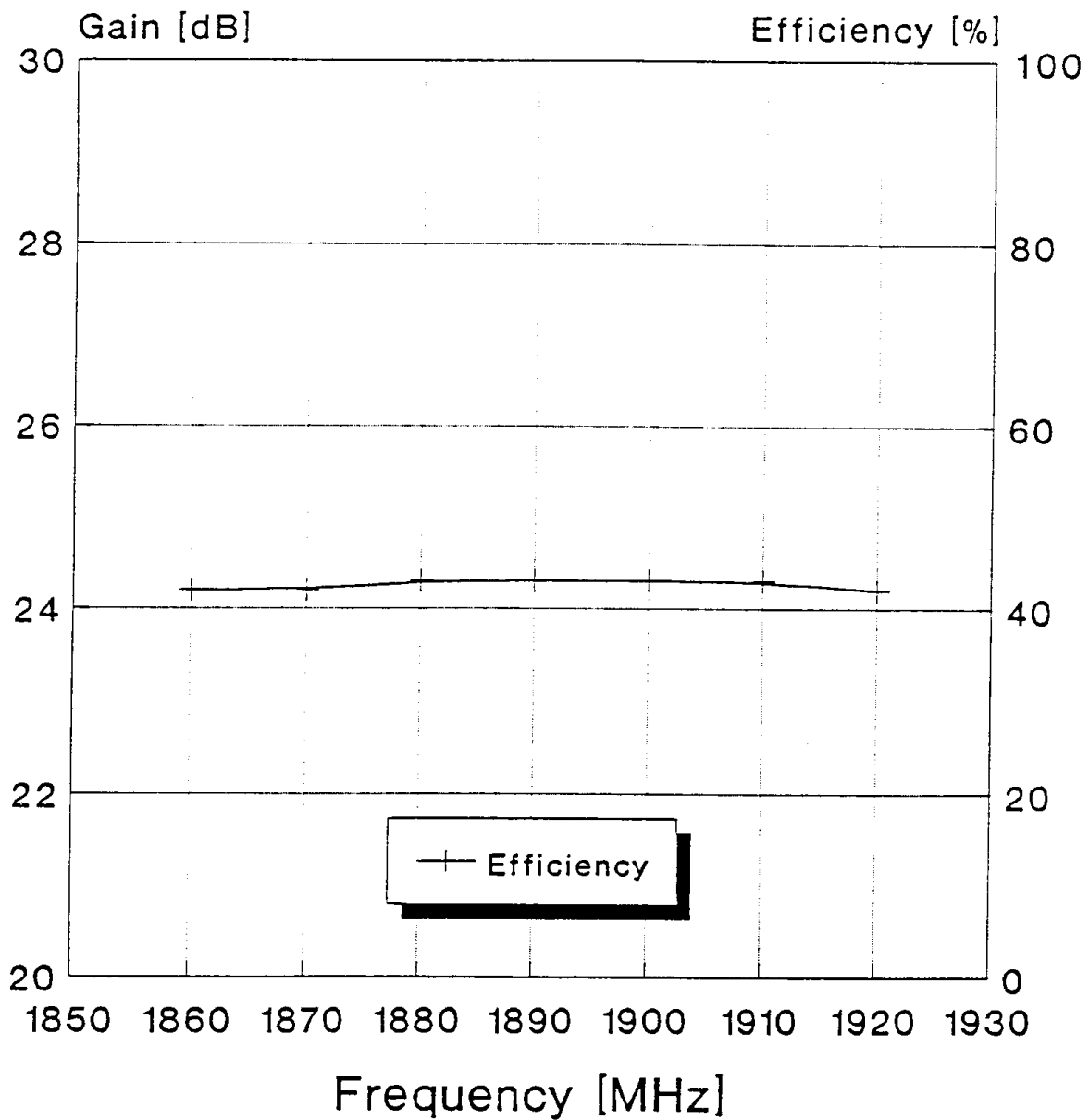

Vs=3.6V, Pin=3dBm, Pout=26dBm
 R06_V04\V005

Pout vs. control voltage

1.9 GHz amplifier

(BFG540/X - BFG10/X - BFG11/X)

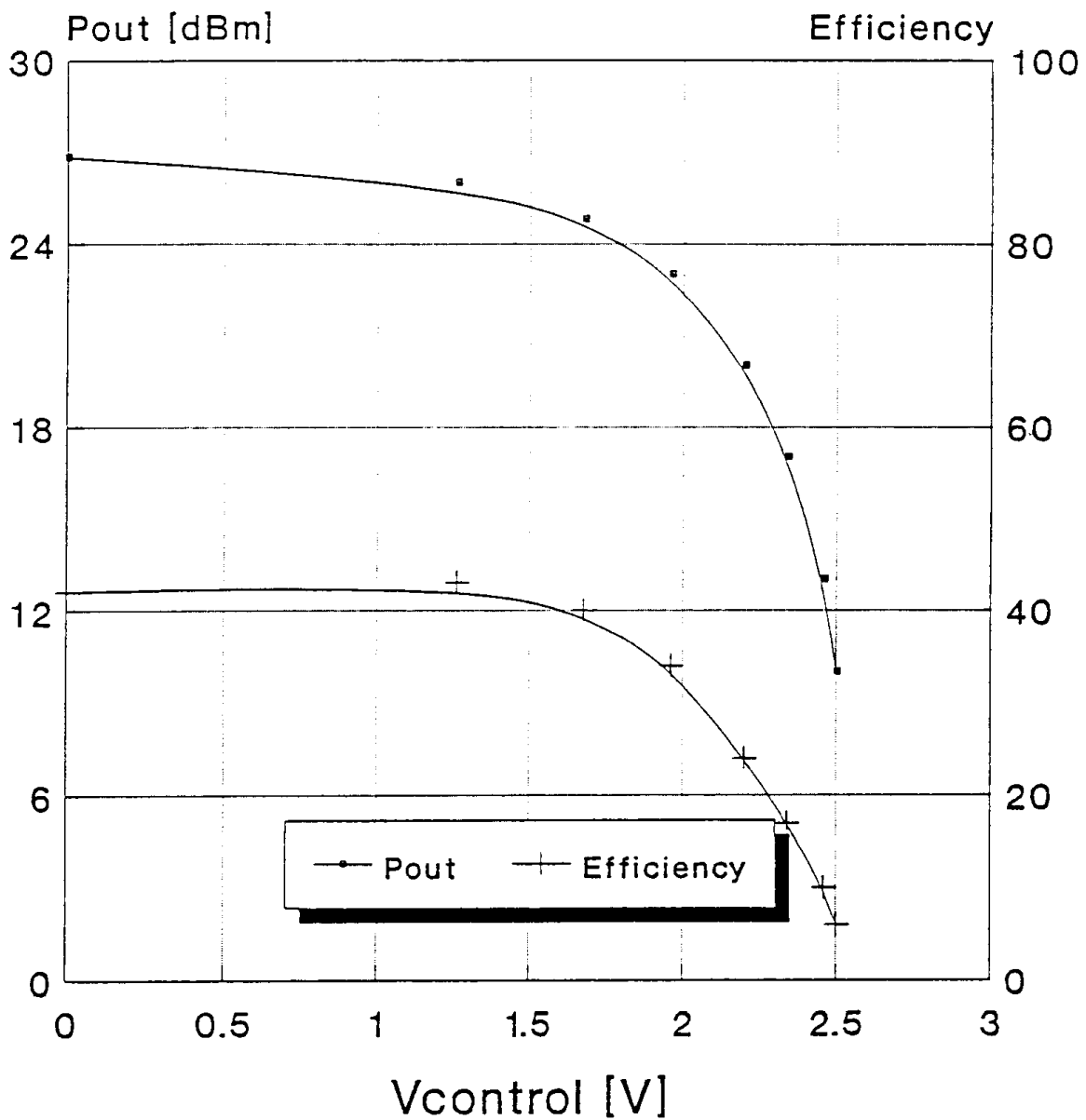

Vs=3.6V, F=1.88GHz, Pin=3dBm
"R06_V05\V007"