



Philips Semiconductors B.V.

Gerstweg 2, 6534 AE Nijmegen, The Netherlands

Reportnr. : RNR-T45-97-B-0584
Author : T.F. Buss
Date : 16-07-97
Department : P.G. Transistors & Diodes, Development

1.5GHz LOW NOISE AMPLIFIER WITH THE BFG425W

Abstract:

This application note contains an example of a Low Noise Amplifier with the new BFG425W Double Poly RF-transistor. The LNA is designed for a frequency $f=1.5\text{GHz}$, $V_{\text{SUP}}\sim 3.8\text{V}$, $I_{\text{SUP}}=5\text{mA}$.

Measured performance at $f=1.5\text{GHz}$: Noise Figure $\text{NF}\sim 1.6\text{dB}$, rf-Gain $S_{21}\sim 14\text{dB}$.

Applications:

- Global Positioning Systems (GPS)
- Satellite Terminals.

Appendix I: 1.5GHz LNA circuit

Appendix II: Printlayout and list of used components & materials

Appendix III: Results of simulations and measurements



Philips Semiconductors B.V.

Introduction:

With the new Philips silicon bipolar double poly BFG400W series, it is possible to design low noise amplifiers for high frequency applications with a low current and a low supply voltage. These amplifiers are well suited for the new generation low voltage high frequency wireless applications. In this note an example of such an amplifier will be given. This amplifier is designed for a working frequency of 1.5GHz.

Designing the circuit:

The circuit is designed to show the following performance (target):

transistor: BFG425W

$V_{ce}=3V$, $I_c=5mA$, $V_{SUP}\sim 3.7V$

freq=1.5GHz

Gain~14dB

NF<=1.6dB

VSWR_i<1:2

VSWR_o<1:2

The in- and output matching is realised with a LC-combination. Also extra emitter-inductance on both emitter-leads (μ -strips) are used to improve the matching and the Noise Figure.

Designing the layout:

A lay-out has been designed with HP-MDS. Appendix II contains the print layout.

Measurements:

Simulations (with realistic RF-models of all used parts) and measurements of the total circuit (epoxy PCB) are done (Appendix III).

Philips Semiconductors B.V.

Appendix I: Schematic of the circuit

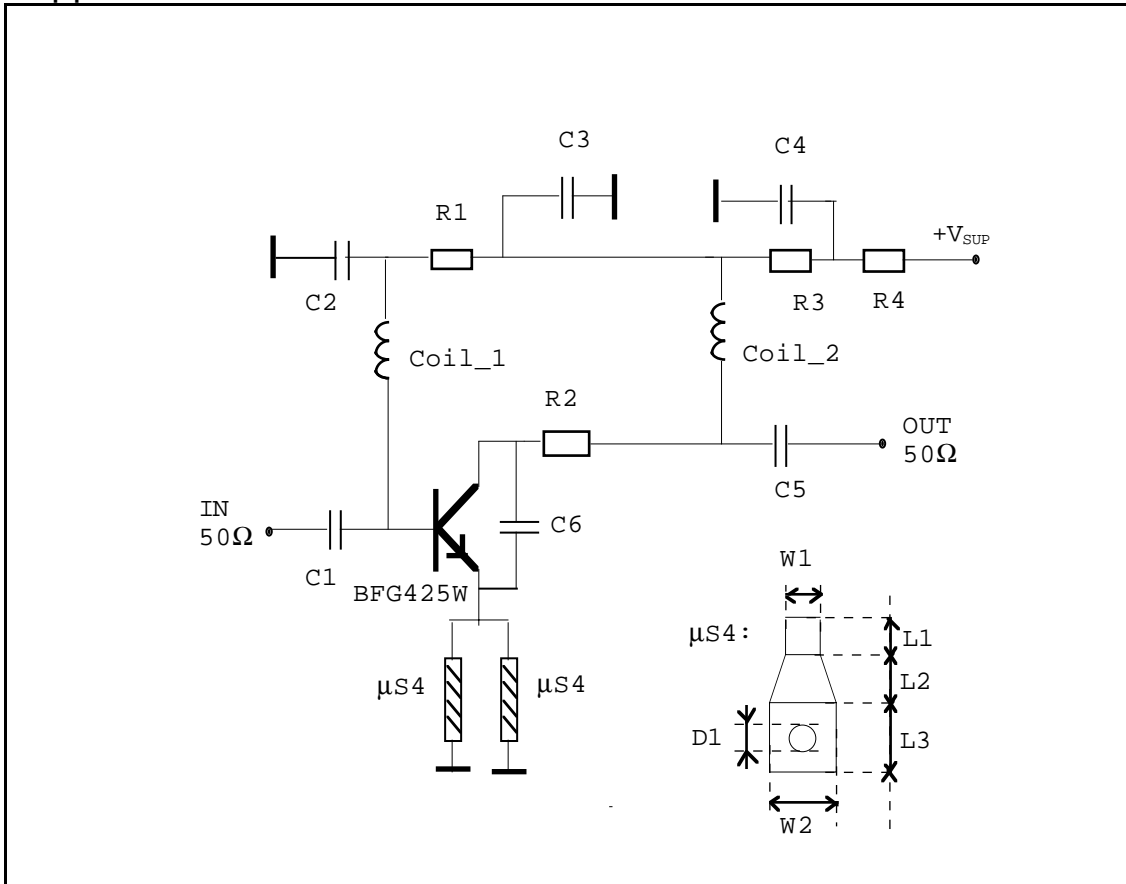

Figure 1: LNA circuit

1.5GHz LNA Component list: 1.5GHz LNA Component list:

Component	Value	Purpose, comment
R1	33 kΩ	Bias (coll.-base)
R2	10 Ω	in series with coll. for better S22, stability and reducing gain.
R3	22 Ω	RF blocking
R4	100 Ω	Bias, series with coll., cancelling hFE spread
C1	3.3 pF	Input match (input to base)
C2	8.2 pF	1.5GHz short (L1 to ground)
C3	8.2 pF	1.5GHz short (L2 to ground)
C4	1 nF	RF decoupling collector bias
C5	82 pF	Output match (collector to output)
C6	1 pF	Output match, stability (collector to emitter)
Coil_1	8.2 nH	Input match (base-bias)
Coil_2	8.2 nH	Output match (collector-bias)
μs4	(see next table)	μ-stripline Emitter-induction



Philips Semiconductors B.V.

μ S4 Emitter inductance of μ -stripline and via-hole (see on formerpage: Schematic of the circuit):

Name	Dimension	Description
L1	2.5mm	length μ -stripline; $Z_0 \sim 48\Omega$ (PCB: $\epsilon_r \sim 4.6$, $H=0.5\text{mm}$)
L2	1.0mm	length interconnect stripline and via-hole area
L3	1.0mm	length via-hole area
W1	0.5mm	width μ -stripline
W2	1.0mm	width via-hole area
D1	0.4mm	diameter of via-hole

Philips Semiconductors B.V.

Appendix II: Printlayout and list of used components & materials

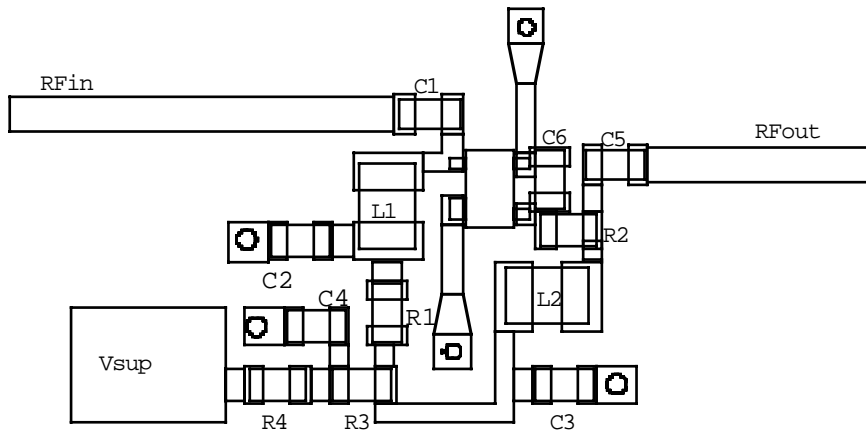

1.5GHz LOW NOISE AMP.

Figure 2: Printlayout

1.5GHz LNA Component list:

Component:	Value:	size:
PCB	FR4: $\epsilon_r \sim 4.6$	H=0.5mm
R1	33 k Ω	0603 Philips
R2	10 Ω	0603 Philips
R3	22 Ω	0603 Philips
R4	100 Ω	0603 Philips
C1	3.3 pF	0603 Philips NPO
C2	8.2 pF	0603 Philips NPO
C3	8.2 pF	0603 Philips NPO
C4	1 nF	0805 Philips
C5	82 pF	0603 Philips NPO
C6	1 pF	0603 Philips NPO
L1	8.2 nH	0805CS Coilcraft
L2	8.2 nH	0805CS Coilcraft

