

APPLICATION INFORMATION

2.4 GHz low noise amplifier with the BFG480W

2.4 GHz low noise amplifier with the BFG480W

ABSTRACT

- Description of the product

The BFG480W is one of the Philips double polysilicon wideband transistors of the BFG400 series.

- Application area

Low voltage high frequency wireless applications.

- Presented application

A low noise amplifier for 2.4 GHz applications such as wireless local area network and wireless local loop.

- Main results

At a frequency of 2.4 GHz, the amplifier has an insertion power gain of approximately 9.5 dB, a noise figure of approximately 3 dB, and a third order intercept point of approximately 17 dBm (measured at input).

© PHILIPS ELECTRONICS N.V. 1999

All rights are reserved. Reproduction in whole or in part is prohibited without the prior written consent of the copyright owner.

The information presented in this document does not form part of any quotation or contract, is believed to be accurate and reliable and may be changed without notice. No liability will be accepted by the publisher for any consequence of its use. Publication thereof does not convey nor imply any license under patent- or other industrial or intellectual property rights.

2.4 GHz low noise amplifier with the BFG480W

INTRODUCTION

With the Philips double polysilicon wideband transistor BFG480W, it is possible to design Low Noise Amplifiers (LNAs) for high frequency applications with a low current and a low supply voltage. These amplifiers are well suited for the new generation low voltage high frequency wireless applications. One feature of the BFG480W is that it has a good linearity performance. Therefore the BFG480W is well suited for LNAs with high linearity demands, such as Code Division Multiple Access (CDMA) systems. This application note gives an example of a 2.4 GHz LNA with the BFG480W. Because this LNA design has a high third order intercept value of 17 dBm (measured at input), it can be used for Wireless Local Area Network (WLAN) front-end and Wireless Local Loop (WLL) applications.

CIRCUIT DESCRIPTION

The following initial conditions apply for the amplifier design:

- $V_{\text{supply}} \approx 3.6 \text{ V}$
- $V_{\text{CE}} = 2 \text{ V}$
- $I_{\text{C}} = 40 \text{ mA}$
- $f = 2.4 \text{ GHz}$.

The circuit is designed to show the following performance:

- $|s_{21}|^2 \approx 9 \text{ dB}$
- $\text{VSWR}_{\text{IN}} < 2$
- $\text{VSWR}_{\text{OUT}} < 2$
- $\text{NF} \leq 3.5 \text{ dB}$
- $\text{IP}_3 > 15 \text{ dBm}$.

The output matching is realised with an LC combination. Also an extra emitter inductance (micro stripline) is used on both emitter-leads to improve the matching and the noise figure.

CIRCUIT DIAGRAM

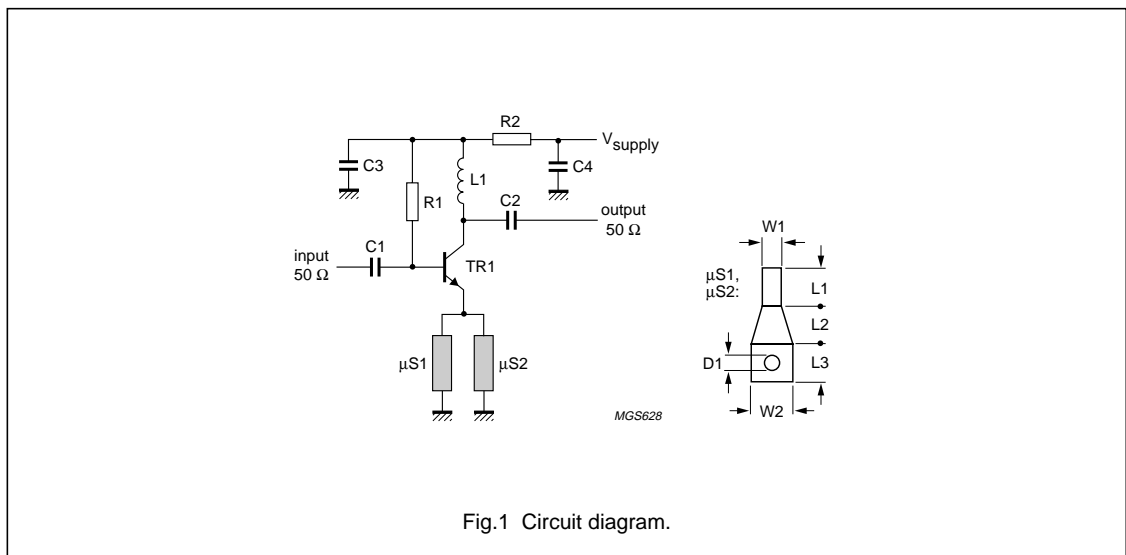

2.4 GHz low noise amplifier with the BFG480W

COMPONENT LIST

Table 1 Component list for the 2.4 GHz LNA

COMPONENT	VALUE	UNIT	SIZE, MANUFACTURER	PURPOSE, COMMENT
TR1	BFG480W		SOT343R Philips	RF transistor
R1	2.7	k Ω	0603 Philips	collector to base bias
R2	39	Ω	0603 Philips	collector series bias; levelling h_{FE} spread
C1	5.6	pF	0603 Philips	input match (base coupling)
C2	3.3	pF	0603 Philips	output match (collector coupling)
C3	5.6	pF	0603 Philips	2.4 GHz short (L1 to ground)
C4	1	nF	0603 Philips	RF collector bias decoupling
L1	150	nH	0805CS Coilcraft	output match
μ S1	see Table 2			emitter induction: micro stripline and via-hole
μ S2	see Table 2			emitter induction: micro stripline and via-hole
PCB	FR4			$\epsilon_r \approx 4.6$, $d = 0.5$ mm

Table 2 Dimensions of the micro striplines μ S1 and μ S2 (see Fig.1)

DIMENSION	VALUE	UNIT	DESCRIPTION
L1	1.0	mm	length micro stripline; $Z_o \approx 48 \Omega$
L2	1.0	mm	length interconnect micro stripline and via-hole area
L3	1.0	mm	length via-hole area
W1	0.5	mm	width micro stripline
W2	1.0	mm	width via-hole area
D1	0.4	mm	diameter of via-hole

2.4 GHz low noise amplifier with the BFG480W

BOARD LAYOUT

Short-circuit wires are used to adapt an existing printed-circuit board, which was developed for low noise applications. The layout has been designed with the Hewlett Packard Microwave Design System (HP-MDS).

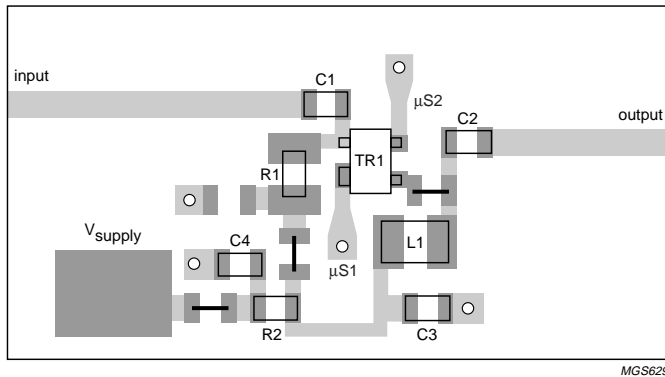

Fig.2 PCB layout.

MEASUREMENTS

The measurements have been done under the following conditions (unless otherwise specified):

- Supply voltage 3.6 V
- Supply current 40 mA
- Frequency 2.4 GHz.

Table 3 Measuring results of the 2.4 GHz LNA

SYMBOL	PARAMETER	CONDITION	VALUE	UNIT
$ s_{21} ^2$	insertion power gain		9.6	dB
$VSWR_{IN}$	input voltage standing wave ratio		1.6	
$VSWR_{OUT}$	output voltage standing wave ratio		1.6	
NF	noise figure		3.0	dB
$IP3_i$	third order intercept point	$P_i = -10$ dBm; $\Delta f = 200$ kHz	17	dBm