

APPLICATION INFORMATION

2.45 GHz power amplifier with the BFG480W

2.45 GHz power amplifier with the BFG480W

ABSTRACT

- Description of the product

The BFG480W, one of the Philips double polysilicon wideband transistors of the BFG400 series. These transistors are characterised by a transition frequency higher than 20 GHz at low supply voltages.

- Application area

Low voltage high frequency wireless applications.

- Presented application

A power amplifier for a 2.45 GHz WLAN.

- Main results

At a frequency of 2.45 GHz, a supply voltage of 3.0 V, and a control voltage of 3.0 V, the amplifier delivers an output power of 19 dBm at an input power of 8 dBm, with a power added efficiency of 38 %.

© PHILIPS ELECTRONICS N.V. 1999

All rights are reserved. Reproduction in whole or in part is prohibited without the prior written consent of the copyright owner.

The information presented in this document does not form part of any quotation or contract, is believed to be accurate and reliable and may be changed without notice. No liability will be accepted by the publisher for any consequence of its use. Publication thereof does not convey nor imply any license under patent- or other industrial or intellectual property rights.

2.45 GHz power amplifier with the BFG480W

INTRODUCTION

With the Philips double polysilicon wideband transistor BFG480W, it is possible to design Power Amplifiers (PAs) for high frequency applications with a low current and a low supply voltage. The transistors have a transition frequency higher than 20 GHz at low supply voltages. This application note gives an example of a power amplifier with the BFG480W for a frequency of 2.45 GHz for a Wireless Local Area Network (WLAN).

PERFORMANCE OVERVIEW

The measurements on the amplifier in the Continuous Wave (CW) mode of operation have been done under the following conditions:

- $V_{\text{supply}} = 3.0 \text{ V}$
- $V_{\text{crt1}} = 3.0 \text{ V}$
- $I_{\text{supply}} = 64 \text{ mA}$
- $P_i = 8 \text{ dBm}$
- $f = 2.45 \text{ GHz}$
- $Z_i = 50 \Omega$; $Z_o = 50 \Omega$.

Table 1 Measuring results of the PA (CW mode of operation)

SYMBOL	PARAMETER	CONDITIONS	VALUE	UNIT
P_o	output power		19	dBm
G_P	power gain		11	dB
η_{PA}	power added efficiency	note 1	38	%
η_{tot}	total efficiency	note 2	41	%
$V_{\text{SWR}_{IN}}$	input voltage standing wave ratio		2	

Notes

1. The power added efficiency is defined as $\eta_{PA} = \frac{P_o - P_i}{V_{\text{supply}} \times I_{\text{supply}}} \times 100\%$.
2. The total efficiency is defined as $\eta_{\text{tot}} = \frac{P_o}{V_{\text{supply}} \times I_{\text{supply}}} \times 100\%$.

2.45 GHz power amplifier with the BFG480W

CIRCUIT DESCRIPTION

The power amplifier operates at a single supply voltage of 3.0 V. It consists of the BFG480W wideband transistor, operating in class AB. Biasing for load power adjustment is performed by an external control voltage and a circuit with an NPN transistor BC817. The BFG480W has two emitter-leads which have to be carefully grounded to ensure stable operation and performance according to the specification. The PCB layout (see Fig.2) of the amplifier results in an emitter-to-ground inductance of 130 pH (typical value).

CIRCUIT DIAGRAM

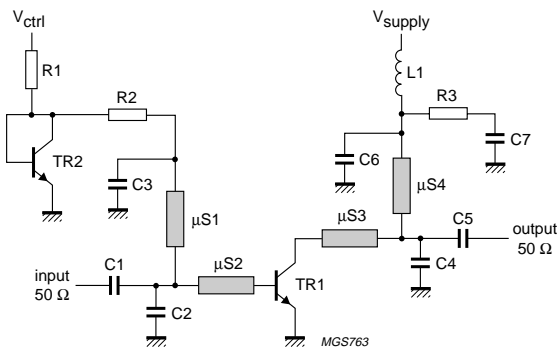

Fig.1 Circuit diagram.

2.45 GHz power amplifier with the BFG480W

COMPONENT LIST

Table 2 Component list for the 2.45 GHz PA

COMPONENT	VALUE	UNIT	SIZE, MANUFACTURER	PURPOSE, COMMENT
TR1	BFG480W		SOT343R Philips	RF transistor
TR2	BC817		SOT23 Philips	NPN bias transistor
R1	680	Ω	0.4 W metal film resistor	
R2	10	Ω	0.4 W metal film resistor	
R3	5	Ω	0.4 W metal film resistor	
C1	6.8	pF	type 100A; see note 1	
C2	2.2	pF	type 100A; see note 1	
C3	6.8	pF	type 100A; see note 1	
C4	1.2	pF	type 100A; see note 1	
C5	6.8	pF	type 100A; see note 1	
C6	6.8	pF	type 100A; see note 1	
C7	4.7	nF	type 100A; see note 1	
L1	4S2			ferroxcube chip bead
μ S1	–		L = 18 mm; W = 0.25 mm	micro stripline; $Z_o \approx 100 \Omega$
μ S2	–		L = 18 mm; W = 0.25 mm	micro stripline; $Z_o \approx 50 \Omega$
μ S3	–		L = 18 mm; W = 0.25 mm	micro stripline; $Z_o \approx 50 \Omega$
μ S4	–		L = 18 mm; W = 0.25 mm	micro stripline; $Z_o \approx 100 \Omega$
PCB	–			$\epsilon_r \approx 6.15$; d = 0.64 mm

Note

1. Multilayer ceramic chip capacitor; American Technical Ceramics or a capacitor of the same quality.

2.45 GHz power amplifier with the BFG480W

BOARD LAYOUT

The double copper-clad PTFE fibre-glass dielectric printed-circuit board has the following specification:

- $d = 0.64$ mm
- $t = 35$ μm (copper cladding thickness)
- $\epsilon_r = 6.15$
- $\tan \delta = 0.0019$
- Dimensions 35×45 mm.

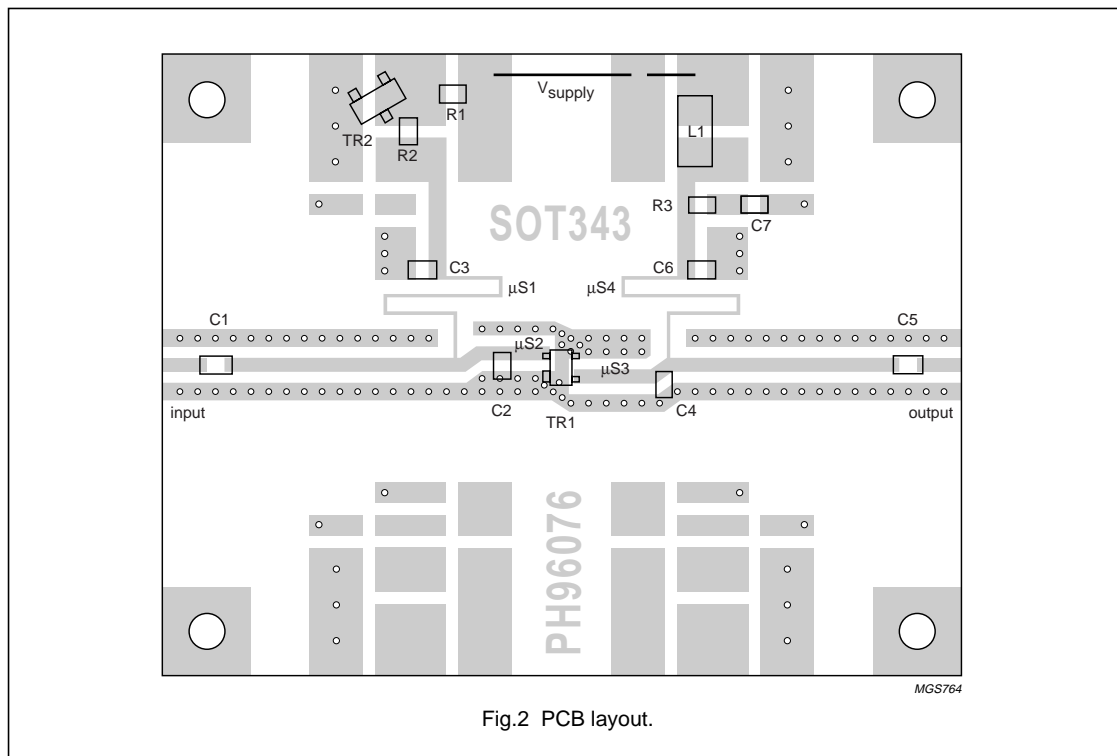

Fig.2 PCB layout.

2.45 GHz power amplifier with the BFG480W

MEASUREMENTS

The measurements in the CW mode of operation have been done under the following conditions:

- Supply voltage 3.0 V
- Control voltage 3.0 V
- Quiescent current 1 mA
- Frequency 2.45 GHz.

The output is optimized for an output level of 19 dBm.

Table 3 Measuring results of the 2.45 GHz power amplifier

P_i (dBm)	P_o (dBm)	G_P (dB)	I_{supply} (mA)	η_{PA} (%)	η_{tot} (%)
0	6.40	6.40	15	7.48	9.70
1	8.80	7.80	19	11.10	13.31
2	10.90	8.90	24	14.89	17.09
3	12.70	9.70	28	19.79	22.17
4	14.30	10.30	34	23.92	26.39
5	15.80	10.80	41	28.34	30.91
6	17.10	11.10	48	32.85	35.62
7	18.20	11.20	56	36.34	39.33
8	19.00	11.00	64	38.09	41.37
9	19.80	10.80	73	39.98	43.61
10	20.50	10.50	83	41.04	45.06
11	21.10	10.10	94	41.22	45.68
12	21.60	9.60	103	41.65	46.78
13	22.20	9.20	113	43.07	48.96
14	22.70	8.70	126	42.62	49.26
15	23.10	8.10	135	42.61	50.41
16	23.40	7.40	140	42.61	52.09
17	23.70	6.70	142	43.26	55.03
18	23.90	5.90	144	42.22	56.82
19	24.20	5.20	146	41.92	60.05
20	24.30	4.30	149	37.84	60.21

2.45 GHz power amplifier with the BFG480W

